

MINOLTA

MAXXUM[®]
DYNAX[™]

7xi

E INSTRUCTION MANUAL

INTRODUCTION

The Minolta DYNAX/MAXXUM 7xi is one of the most innovative AF SLRs available. For this reason, you are holding a large and rather intimidating owner's manual. However, not everything will pertain to you immediately, so read it in sections.

First, look over the parts diagrams and familiarize yourself with the controls, their names, and their locations. This will be helpful later when they are introduced in the manual and you learn about their functions. Next, read Preparations, beginning on p.8. Follow along and attach the strap, insert a battery, etc. Get used to holding the camera, working the controls, and seeing the displays.

Then, begin where you must with anything new — The Basics. Read it well, and you should then be ready to put the 7xi to work for you in the simplest way possible. As you use the camera, you will begin to realize the power of features such as:

- Expert system programming with fuzzy logic control
- High-Speed, Multi/Omni-Dimensional Predictive autofocus
- Expert Program Selection
- Graphic Display Viewfinder
- Creative Program Control

Operations in Detail and the Appendix are there for you to increase your mastery over this unique camera and its innovative technology, and to help you expand your control over the medium of photography.

IMPORTANT INFORMATION

The Minolta DYNAX/MAXXUM 7xi was designed to work specifically with lenses, flash units, and other accessories manufactured and distributed by Minolta. We therefore caution users of this camera that the attachment and/or use of incompatible products with the 7xi may result in unsatisfactory performance or damage to the camera or its accessories. To obtain optimum performance throughout the life of your DYNAX/MAXXUM 7xi, we recommend that you use only those lenses, flashes and other accessories distributed by Minolta specifically for use with this camera.

STATEMENT OF FCC COMPLIANCE

This device complies with Part 15 of the FCC Rules. Operation is subject to the following two conditions: (1) This device may not cause harmful interference, and (2) this device must accept any interference received, including interference that may cause undesired operation. Changes or modifications not approved by the party responsible for compliance could void the user's authority to operate the equipment. This equipment has been tested and found to comply with the limits for a Class B digital device, pursuant to Part 15 of the FCC Rules. These limits are designed to provide reasonable protection against harmful interference in a residential installation. This equipment generates, uses and can radiate radio frequency energy and, if not installed and used in accordance with the instructions, may cause harmful interference to radio communications. However, there is no guarantee that interference will not occur in a particular installation. If this equipment does cause harmful interference to radio or television reception, which can be determined by turning the equipment off and on, the user is encouraged to try to correct the interference by one or more of the following measures: Reorient or relocate the receiving antenna.

Increase the separation between the equipment and receiver.

Connect the equipment into an outlet on a circuit different from that to which the receiver is connected. Consult the dealer or an experienced radio/TV technician for help.

STATEMENT OF DOC COMPLIANCE

This digital apparatus does not exceed the Class B limits for radio noise emissions from digital apparatus as set out in the Radio Interference Regulations of the Canadian Department of Communications.

TABLE OF CONTENTS

INTRODUCTION	1
NAMES OF PARTS	4

PREPARATIONS

Neckstrap	8
Eyepiece Cap	9
Lens	10
Attaching	10
Removing	11
Care of glass surfaces	11
Battery	12
Inserting	12
Battery-condition indicators	13
Battery Performance	14
Cold-weather operation	14
Film	15
Loading	15
Automatic/manual film speed setting	18
Automatic/manual rewind	20

SIMPLE OPERATION – THE BASICS

Holding the Camera	22
Taking Pictures	23
Camera-Shake Warning	25
Autofocus	26
Focus Signals	27
Focus Lock	28
Programmed Autoexposure	29
Creative Program Control	31
PA	32
Ps	35

OPERATIONS IN DETAIL

Main Switch and Eye-start	39
Focusing Details	40
Autofocus illuminator	40
Local AF area selection	41
Special focusing situations	43
Manual focus	44
Exposure Details	46
<i>Changing exposure mode</i>	46
Aperture priority	48
Shutter priority	50
Manual exposure	52
Metering modes	54
Exposure compensation	56
AE lock	58
Self-timer	59
Bulb	60
Flash System	62
Flash modes	62
P mode flash	64
A, S, and M mode flash	65
Slow-shutter sync flash	68
Remote/Wireless off-camera TTL flash	70
Film drive	74
Autozoom	76
Auto stand-by zoom	76
Image-size lock	78
Wide-view mode	80

APPENDIX

Lens Aperture and Depth of Field	84
Shutter Speed and Moving Subjects	87
Composition	88
Accessory Information	90
Care and Storage	92
Troubleshooting	94
Technical Description	95
Quick Reference Guide	98

Names of Parts/Body

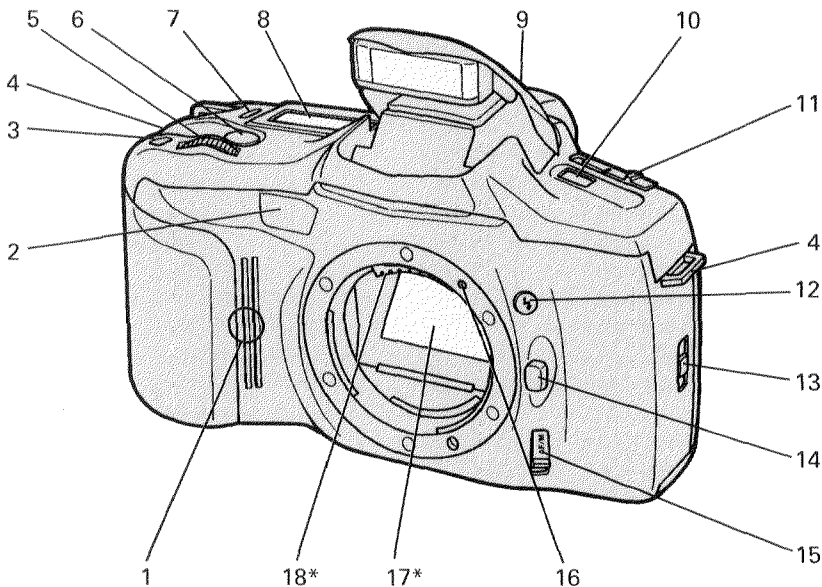

- | | |
|------------------------------------|------------------------|
| 1. Grip sensor | 13. Back-cover release |
| 2. AF illuminator/self-timer light | 14. Lens release |
| 3. Wide-view mode button | 15. Focus-mode switch |
| 4. Strap eyelet | 16. Mounting index |
| 5. Front control dial | 17. Mirror* |
| 6. Shutter-release button | 18. Lens contacts* |
| 7. Card on/off button | 19. Film chamber |
| 8. Body data panel | 20. Eyepiece sensor |
| 9. Accessory shoe | 21. Eyepiece cup |
| 10. Program-reset button | 22. AE Lock button |
| 11. Main switch | 23. Rear control dial |
| 12. Flash pop-up button | 24. Function button |
| | 25. Film window |

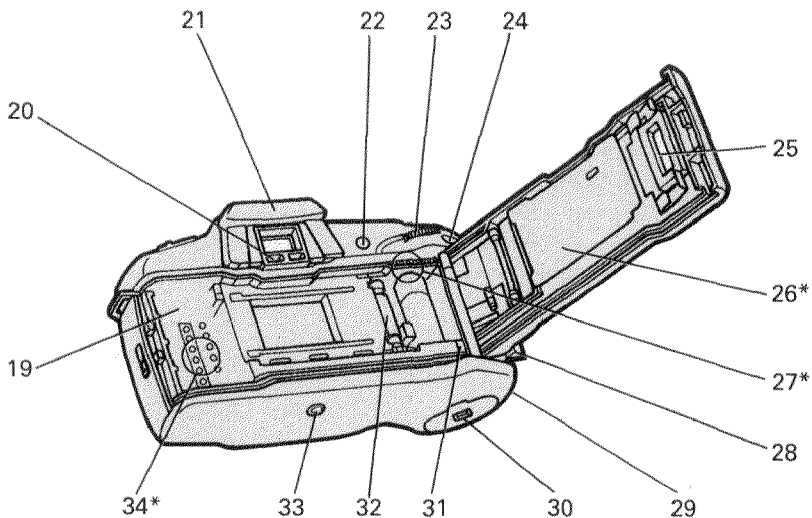

- 26. Pressure Plate*
- 27. Accessory-back contacts*
- 28. Card door
- 29. Remote-control terminal
- 30. Battery-cover release
- 31. Film-leader index
- 32. Sprocket
- 33. Tripod socket
- 34. DX contacts*
- 35. Self-timer/Drive mode button
- 36. Flash-mode button
- 37. Rewind button
- 38. ISO button
- 39. Card-adjust button
- 40. Card-eject slide

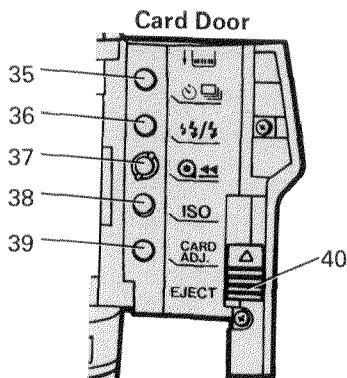

*Do not touch

Names of Parts/Body LCD

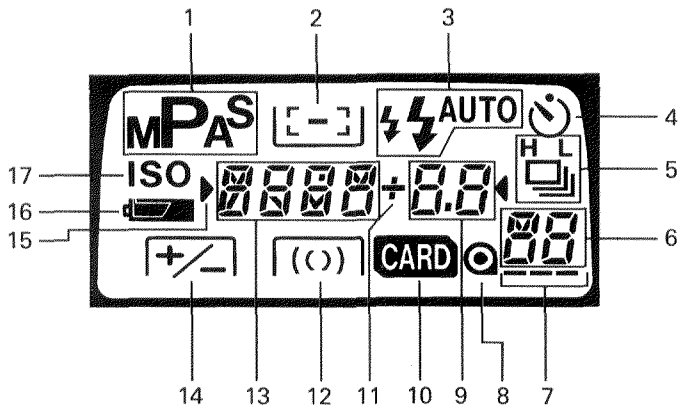

1. Exposure-mode indicators
2. Wide/Local focus indicator
3. Flash-mode indicators
4. Self-timer indicator
5. Drive-mode indicators
6. Frame counter
7. Film-transport signals
8. Film-cartridge mark
9. Aperture/Exposure Adjustment/Card setting displays
10. Card indicator
11. Exposure-adjustment indicator
12. Metering-mode indicators
13. Shutter-speed/film-speed/card name displays/
local-AF-area indicators
14. Exposure-adjustment reminder
15. Selectable Setting Pointers
16. Battery-condition indicator
17. Film-speed mark

Names of Parts/Viewfinder Screen

1. Image-size-lock indicator
2. Dial-function indicators
3. Wide-view indicator
4. Film-frame indicator
5. AF-area indicator
6. Local-AF-area indicator
7. Spot-metering area
8. Manual-focus indicator
9. Depth index
10. Action index
11. Panorama indicator
12. Image control index

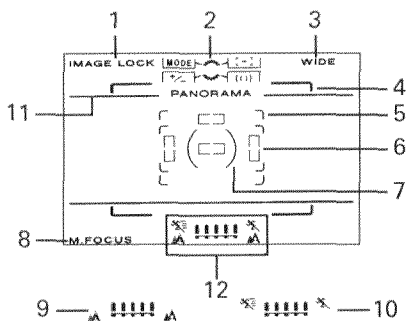

Names of Parts/Viewfinder Data Panel

1. Flash-on indicator
2. Flash-mode indicator
3. Camera-shake warning
4. Focus signals
5. Exposure-mode indicators
6. Shutter-speed/Film-speed display
7. Exposure Signals/Exposure Adjustment indicator
8. Aperture/Exposure Adjustment display
9. AEL indicator

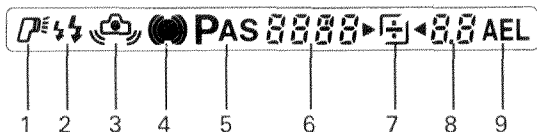

PREPARATIONS

NECKSTRAP

A neckstrap is supplied with your camera. Attach it as shown below.

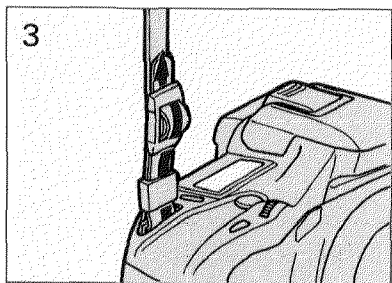
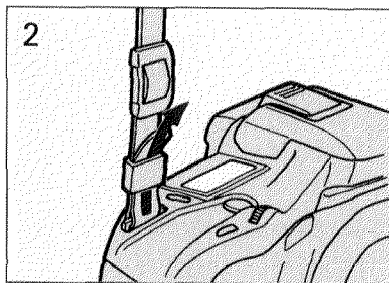
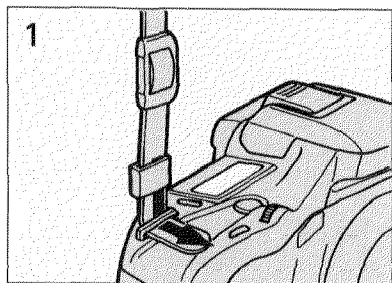

EYEPiece CAP

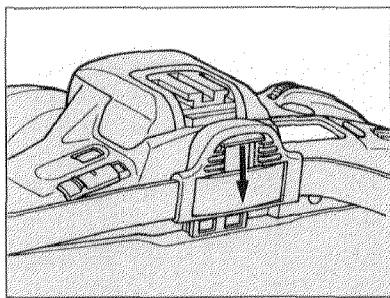
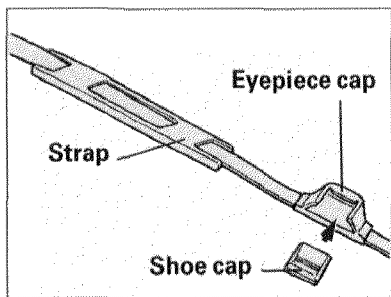

An eyepiece cap is also included on the strap. It fits over the eyepiece to prevent stray light from entering the camera and affecting the exposure during situations in which you are not looking through the viewfinder when the shutter releases (ie, self-timer photographs or bulb exposures). An accessory shoe cap protects the contacts on the camera's accessory contacts from dust and dirt. When you are using a flash or other accessory, slide the accessory shoe cap into the eyepiece cap for safekeeping.

LENS

To attach:

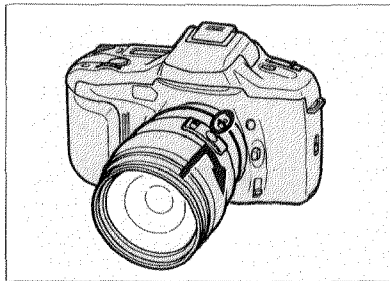
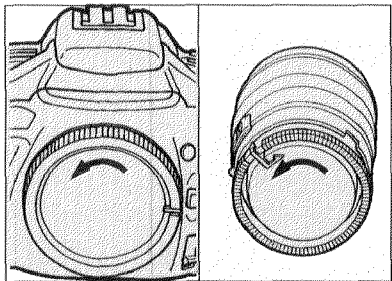

1. Remove body cap and rear lens cap as shown.
2. Align the red bead on the lens barrel with the red dot on the camera's lens mount. Gently insert the lens into the mount and turn the lens clockwise until it locks in place with a click.

● If no lens is attached to the camera, if the lens is not attached properly, or if the AZ/MZ switch on an xi-Series lens is set to MZ, "--" will appear in the body data panel and in the aperture display of the viewfinder data panel when Eye-Start activates the camera (below).



To remove:

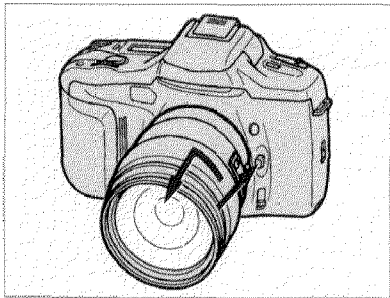

1. While pressing the lens release, turn the lens counterclockwise until it stops. Lift the lens out of the mount.
2. Immediately attach the rear cap to the lens and the body cap or another lens to the camera. This will protect the camera interior, lens contacts, and lens elements.

Be careful. . .

- Do not force the lens onto the body if it does not turn smoothly.
- Never touch anything inside the camera, especially the lens contacts and mirror.

Care of Glass Surfaces

- Never touch any lens surfaces (including the eyepiece) with your fingers. If a lens becomes dirty, first gently clean it with a lens brush. Then, if necessary, moisten a sheet of lens tissue with one drop of lens-cleaning fluid and, starting from the center of the lens, wipe the glass in a circular motion.
- Never lift the mirror or touch its surface, as this may impair its alignment or scratch its face. Dust on the mirror's surface will not affect meter readings or picture quality. If it is distracting, have the camera cleaned at an authorized Minolta service facility.

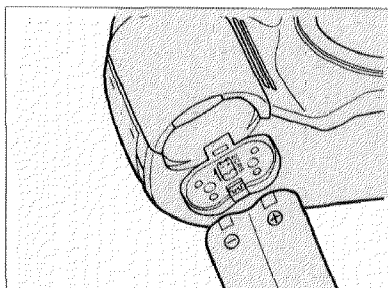
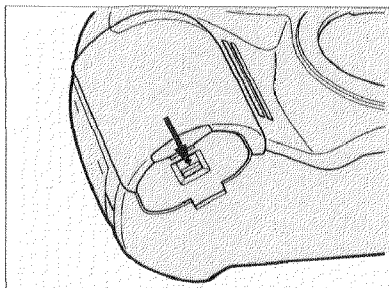

The camera uses a 6-volt 2CR5 lithium battery which supplies power for all camera operations. If you are using an xi-Series lens, the camera battery also supplies power to the lens zoom motor.

Installation

1. With the main switch in the LOCK position, slide the battery cover release in the direction indicated to open the battery cover.
2. Insert the battery according to the marks on the inside of the chamber cover.
3. Snap the cover closed.



- Sometimes it helps to wipe the battery terminals with a clean, dry cloth in order to ensure proper contact.

CAUTION

- Read and follow all warnings and instructions supplied by the battery manufacturer.
- Do not attempt to disassemble, recharge, or short-circuit the battery. Do not subject it to high temperatures or fire. The battery may explode and cause severe burns.
- Keep batteries away from children.

Battery-condition Indicators

At various times during operation, one of the following indicators will appear in the body data panel.

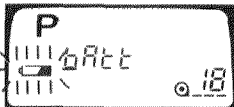
Display	Indication	Meaning
	1. Full-battery symbol appears for 4 sec. after you turn camera on.	Power is sufficient.
	2. Low-battery symbol appears for 4 seconds after you turn camera on.	Power is sufficient, but getting low. Keep a fresh battery handy.
	3. Low-battery symbol blinks while it appears with other operating indicators at any time during use.	Camera can be operated, but power is extremely low. The battery will need to be changed soon.
	4. Blinking low-battery symbol and "bAtt" appears, or no display appears at all, and shutter locks	Power is insufficient for operation. Replace the battery or check that the battery is inserted correctly.

- If no display appears when the main switch is set to ON, double-check that the battery is inserted correctly before inserting a fresh one.

Battery Performance

The 6-volt 2CR5 lithium battery should provide sufficient power for shooting approximately 50 rolls of 24-exposure film without flash or approximately 25 rolls if you use the built-in flash on 50% of the exposure. These figures are based on Minolta's standard test method using a fresh battery at 68° F (20°C). Actual battery performance will depend on how you use the camera. If you install a new battery that has been in prolonged storage, battery performance may vary.

Cold-Weather Operation

Lithium batteries provide excellent performance in cold weather. However, if you plan to shoot many rolls of film outdoors at temperatures near or below 32° F (0°C), we recommend that you carry the camera inside your coat while you are not shooting, to keep it warm. You may also want to carry a spare battery in your pocket so that you can change the camera battery if necessary. Do not discard a cold battery. After it warms up, it will regain some of its charge.

Loading Film

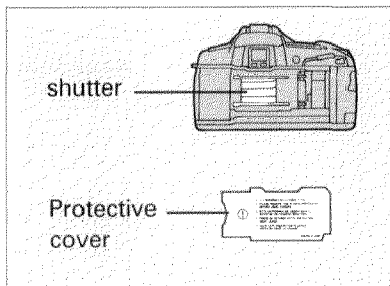
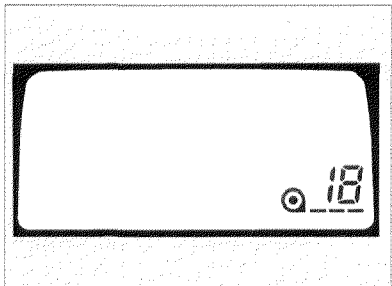

Before you load film, always check the body data panel. If the film cartridge is displayed, **do not open the back cover**. Check the film window and frame counter to verify the type of film in the camera and the number of frames remaining. (See p.20 for instructions on rewinding a partially exposed roll of film.)

- Before you load film for the first time, remove and discard the protective plastic cover over the shutter.
- Always load film in subdued or shaded light.

—NEXT PAGE—

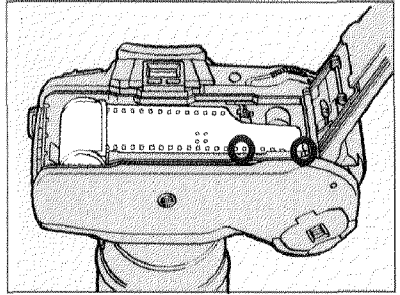
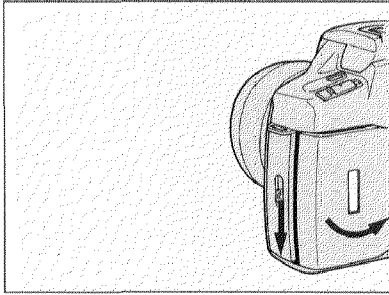

1. Open the back cover by sliding the back-cover release downward.
2. Place the film cartridge into the film chamber as shown above and extend the leader between the guide rails until the tip is just past the film-leader index. Make sure the holes in the film's lower edge are engaged by the sprocket teeth.



RIGHT

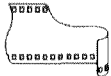

WRONG

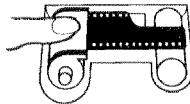

RIGHT

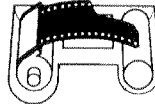

WRONG

- Make sure the film leader is shaped correctly, otherwise the film may not wind properly. Trim a torn or crimped film tip so that it looks like the correct one pictured above left.
- If the film extends too far, gently push the excess back into the cartridge.
- **NEVER TOUCH THE SHUTTER CURTAIN WITH YOUR FINGERS OR WITH THE FILM TIP.** Its precision design makes it extremely sensitive to pressure.

—NEXT PAGE—

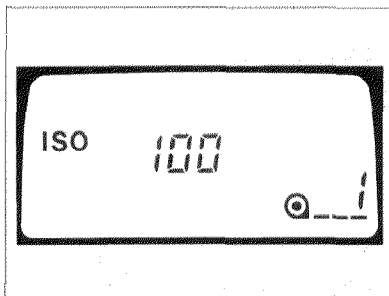
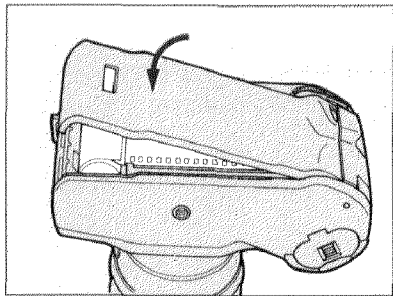

3. Close the back cover and move the main switch to **ON**. The camera will automatically advance the film to the first frame and **1** will appear in the film counter.

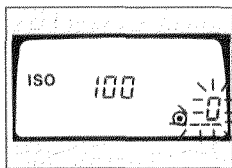

- If the film is loaded incorrectly, **0** will blink in the frame counter and the shutter will remain locked. Open the back cover and repeat steps 2 and 3.

- If you turn the main switch to ON before you load film, do not touch the grip sensor during the above procedures.

Automatic Film Speed Setting

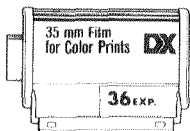

If you use DX-coded film between ISO 25 and 5000, the camera will automatically set the correct film speed. The film speed setting will be displayed in the body data panel for 4 sec. after you load the film.

Manual Film Speed Setting

If you are using a non-DX-coded film or if you wish to override the automatic setting, you must manually set the film speed. The camera will initially set non-DX-coded film to the ISO of the previous roll; initially this value is set to 100.

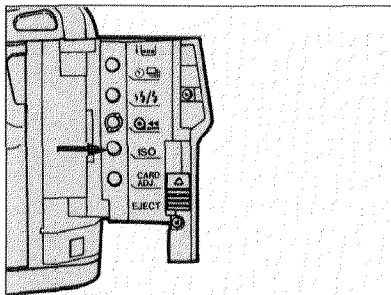
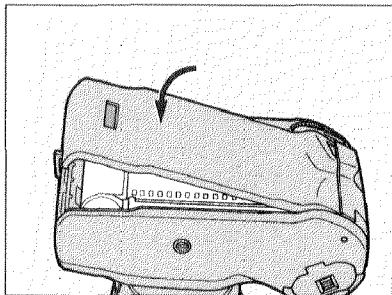

1. Load the film and close the back cover.
2. Open the card door and press the ISO button.

—NEXT PAGE—

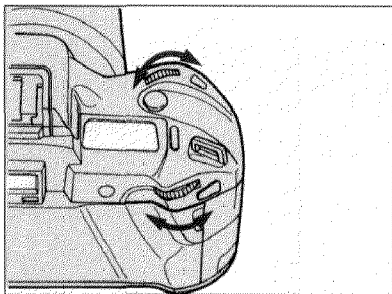

3. Turn either control dial until the desired film speed setting appears in the body data panel.

- Each click of the dials will change the film speed setting by 1/3-stop between ISO 6 and 6400.

4. Press the ISO button again to enter your selection and return to operating mode, or wait 4 sec. and the setting will be entered automatically.

- To check the film speed setting at any time during operation, press the ISO button. The ISO-speed will appear in the body data panel

- For flash exposures, Minolta recommends that you use film between ISO 25 and 1000.

Automatic Rewind

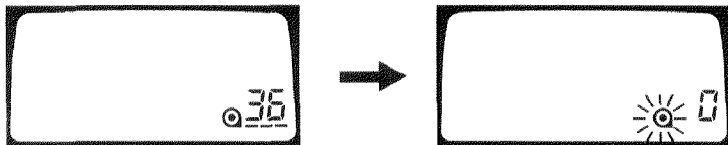

After you have exposed the last frame, the camera will automatically rewind the film. With a fresh battery, it takes about 9 sec. to rewind a 36-exposure roll, or 6 sec. for a 24-exposure roll. When the film has been completely rewound, the motor will stop and the film-cartridge symbol in the body data panel will blink to indicate that it is safe to open the camera back.

Manual Rewind

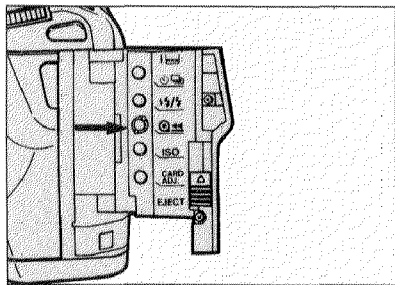

To begin rewind at any time, open the card door and press the rewind button.

- If the motor stops before the film is completely rewound, insert a fresh battery.

SIMPLE OPERATION – THE BASICS

This brief section explains the simplest way to use your new camera—with programmed autoexposure, autofocus, autoflash, and single-frame advance. Details on each of the camera's functions begins on page 38 in the section entitled "Operation in Detail".

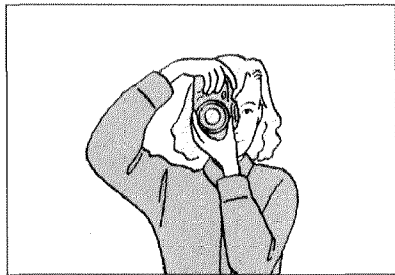
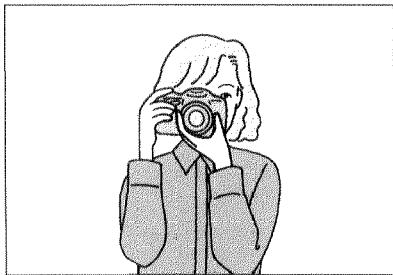

Hold the grip firmly in your right hand and use your left hand to support the camera or lens. Keep your elbows securely against your sides when shooting both horizontal and vertical pictures. Press the shutter-release button gently in a single, steady motion — never with a quick jab. Always keep the camera strap around your neck or wound around one wrist.

- When you pick up the camera, make sure you touch the grip sensor. Otherwise, Eye-Start will not function.
- Do not touch the focusing ring of an AF lens or the end of the lens barrel of an xi-Series Autozoom lens.
- Do not block the AF illuminator when you are using autofocus.

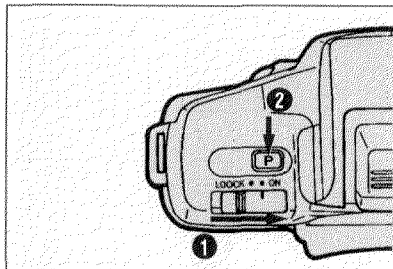

1. Slide the main switch to **ON** and press the program-reset button to set full-automatic operation.

● Pressing the program-reset button sets the camera to programmed autoexposure mode, honeycomb-pattern metering, autofocus, single-frame film advance, $+/-0.0$ exposure compensation, wide autofocus area, and auto switchover flash. Many of these default positions can be changed with the Customized Function Card-xi.

—NEXT PAGE—

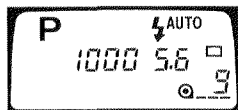
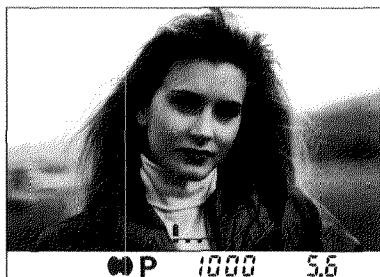

2. Hold the camera as described on p.22.
 3. Look through the eyepiece, place your subject somewhere within the autofocus area, and press the shutter-release button down to take the picture.
 4. After the exposure has been made, the camera will automatically advance the film to the next frame and increase the film counter by one.
- The focus signal will light in the viewfinder data panel when your subject is in focus. See p.27 for a list of focus signals.
 - If you do not touch the grip sensor you must activate AF and AE by pressing the shutter-release button partway down. Again, the in-focus signal will light when the camera has focused on a subject.
 - If the focus signal blinks in the viewfinder data panel, you must focus on something else that is the same distance from you as your subject or else focus the lens manually. Refer to p.43 for more information.

CAMERA-SHAKE WARNING



When your subject or scene is too dark to allow a clear hand-held photograph, the camera-shake warning will blink in the viewfinder data panel. The built-in flash will pop-up automatically, if it is required, when you press the shutter-release button partway down and will fire when you take the picture. You should also consider using a tripod.

- More information on flash operation in all exposure modes can be found beginning on p.62.

Autofocus (AF)

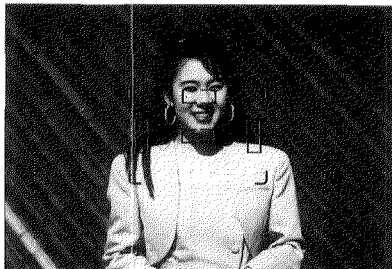

The autofocus system uses expert programming and fuzzy logic to determine which of the AF sensors is detecting your main subject. The camera's ultra-wide AF area has four sensors—two vertical and two horizontal. When you hold the camera horizontally, all four sensors are active; when you hold the camera vertically, the top horizontal sensor shuts off and the AF area changes to its vertical mode.

Focus Signals





When the camera is activated, either by Eyestart or by pressing the shutter-release button partway down, the AF system immediately begins evaluating the scene to determine the location of your subject within the frame. One of the following focus signals will be displayed in the viewfinder data panel:

	Continuous AF mode/focus is confirmed
	Focus is locked
	Focus cannot be confirmed.

- No indicator will be displayed while the lens is focusing.
- If your subject is moving, the camera will automatically enter continuous autofocus mode. In this mode, the autofocus system will repeatedly check and update focus until you press the shutter-release button all the way down. At that time, the camera will predict where the subject will be when the shutter actually makes the exposure and will set the lens to this point so that even high-speed subjects shot in continuous drive mode will remain in focus. (see Focus Lock, next page)
- If your subject is stationary when Eye-start first activates the autofocus system, the camera will enter continuous mode. It will remain in continuous mode if your subject moves before you press the shutter-release button partway down. Focus will lock if it remains stationary.
- In autofocus mode, if focus cannot be confirmed, the shutter will not release.



If, as a result of the composition or framing you have chosen, your subject falls outside the main AF area, use focus lock to lock focus on it, then recompose the scene as desired.

1. Place your subject in the center of the AF area and press the shutter button partway down.
 - Wait for the focus signal to change from  to .
2. Hold the shutter button in this position, recompose the picture, and press the shutter button all the way down to take the picture.



P mode is designed to be the camera's primary exposure mode and is ideally suited for almost all situations. Expert Program Selection analyzes the scene, taking into account subject size, motion, and magnification as well as lens focal length, and sets both the shutter speed and aperture accordingly. It is able to recognize many different photographic situations, from landscapes to close-ups, portraits to action shots, and will optimize the exposure settings based on the particular requirements of the situation at hand. There is no single program line for each focal length, and no special modes to set manually for different situations. Creative Program Control lets you quickly change the programmed exposure settings to obtain a desired effect in your photographs.

—NEXT PAGE—

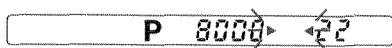
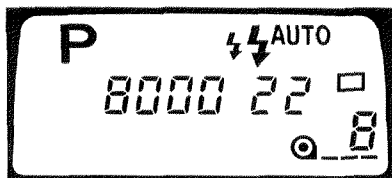
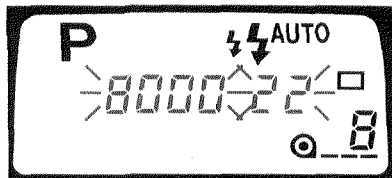

- If the aperture and shutter speed displays blink in the viewfinder and body data panels, then the required exposure settings are beyond the coupling range of the camera and lens.

- If the metering indicators ► ◀ blink in the viewfinder data panel, the lighting is beyond the range of available aperture and shutter speeds. In bright light, attach a neutral density filter.

PA/Ps: CREATIVE PROGRAM CONTROL

As already mentioned, Expert Program Selection will determine the best combination of shutter speed and aperture for almost any scene or situation. If, however, you would like to use a different shutter speed or aperture, the dual-dial control system makes it quick and easy for you to make the desired changes. Furthermore, as you change the aperture or shutter speed, the image control index in the bottom of the viewfinder will show you what effects your adjustments will have on the final image.

- If  appears in the viewfinder data panel, Creative Program Control will not function until you manually cancel the flash or until the flash is no longer necessary.
- The built-in or an attached flash will not function in PA or Ps. If you press the flash control button either to pop-up the built-in flash or to manually fire an accessory flash, the camera will return to P mode.

PA

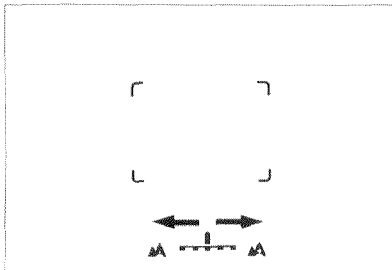
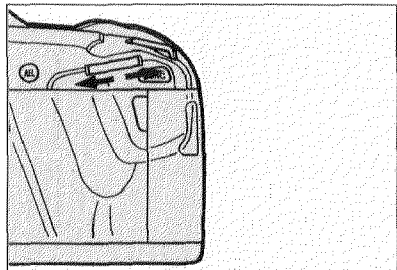

In both P mode and PA, the depth index at the bottom of the viewfinder screen will show roughly how in-focus the background will appear in your final print. If the indicator is all the way to the right, everything from your main subject to infinity will be in focus. If the indicator is to the left, only your subject will be sharp.

When you move the rear control dial, you can change the aperture setting of the programmed exposure and, if the proper shutter speed is available, the camera will maintain a correct exposure. At the same time, the indicator in the depth index will move to show you approximately how your changes will effect your photo.

- If you do not touch any of the camera controls for 30 sec., the camera will return to P mode automatically.
- The shutter speed display will blink if the required speed is beyond the camera's range. If "8000" blinks, move the indicator to the right; if "30" blinks, move the indicator to the left.
- If the metering indicators ► ◀ blink in the viewfinder data panel, the light level is beyond the coupling range of the camera and lens. In bright light, attach a neutral density filter; in low light, return to P mode.

—NEXT PAGE—

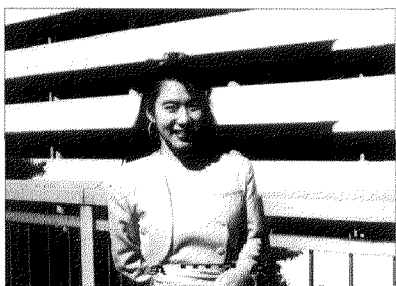
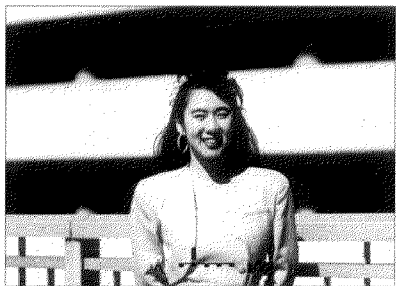
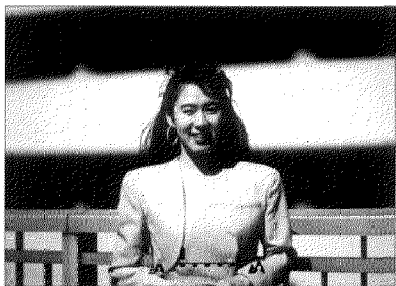

—NEXT PAGE—